

www.dicabs.com

DICABS
POWERING PROGRESS

EHV
(XLPE CABLES)
TECHNICAL CATALOGUE



DICABS



Contents

About Us 01

High Insulation Cables - FR/FRLS / ZHFR 03

FR (Flame Retardant) PVC Insulated Wire & 06

Cables/Single Core Unsheathed Cable 05

Multi Core Flexible Cable - IS 694 : 2010 Voltage 06

Grade up to 1100V/1100V

Some Useful Electrical Data 07



ABOUT US :

Starting out as a fledgling ACSR conductor manufacturing facility in 1970, Diamond Power Infrastructure Limited (DICABS), an ISO 9001/2015, ISO 45001/2018, ISO 14001/2015 certified company, has grown to become India's largest & truly registered integrated manufacturer of power transmission equipment. Our journey from modest beginnings to industry leadership is a testament to our unwavering commitment to quality, innovation, and excellence.

> Our Vision

Looking forward, we are excited about the opportunities that lie ahead. With our strong foundation, extensive expertise, and commitment to excellence, DICABS is poised to continue its leadership in the power transmission and distribution sector. We are committed to exploring new horizons, embracing new technologies, and delivering value to our customers, stakeholders, and the community at large.

> Powering India's Growth

Today, DICABS is proud to play a crucial role in powering India's growth. Our comprehensive range of products and services, coupled with our relentless focus on innovation and quality, makes us the preferred partner for power transmission and distribution projects across the country. Our dedication lies in driving progress and contributing to the development of a robust and reliable power infrastructure for the nation.

> Unmatched Manufacturing Process

A highly skilled team operates advanced manufacturing facilities to produce high-quality power transmission products. Utilizing imported machinery like CNC-controlled extruders, the company manufactures HT XLPE power cables up to 400 KV with precision. DICABS is India's largest manufacturer of MV and EHV cables, meeting standards for medium and high voltage solutions in the power industry.

> Comprehensive Product Range

DICABS offers solutions that span the entire value chain of power transmission and distribution. Our product range covers majority of the T&D infrastructure requirements, ensuring that we can provide integrated solutions for a wide variety of projects. We design our products to meet the highest standards of reliability and performance, from conductors and transformers to cables and insulators. Under the brand name "DICABS," we stand as one of India's leading manufacturers of high-quality HT/LT XLPE and PVC Power, Control, and Aerial Bunched Cables up to 400 KV rating.

> Leadership in Power Transmission

DICABS, India's largest single-integrated power equipment manufacturer, holds a leadership position in the power transmission and distribution sector. Our extensive experience, coupled with our state-of-the-art manufacturing unit at Vadadala near Vadodara, Gujarat, positions us uniquely in the market to cater to the growing demands of the power sector.

> State-of-the-art testing facilities

Quality and reliability are paramount to us. Our world-class EHV Testing Facility, NABL-approved, is capable of testing power cables up to 400 KV, making it a unique asset in the country. Additionally, our cables are rigorously tested by leading laboratories such as CPRI, ERDA, RTC, NTH, DTH, TAG CORPORATION, ATCC, and GTAS, ensuring top-notch quality and reliability

> Pioneering Innovations

Innovation is at the heart of everything we do. Over the years, we have introduced numerous path-breaking technologies and proactive solutions that have set new benchmarks in the industry. Our commitment to continuous improvement and our ability to pioneer newer technologies have been key drivers of our exponential growth and success



DICABS

PREFACE - 66kV 550kV XLPE CABLES

'Dicabs' is one of the world's leading manufacturers of Extra High Voltage cables and also one of a few total solution providers of underground transmission systems. We have decades of heritage as a cable manufacturer, along with in-depth capabilities and facilities to research, design, develop and manufacture products and solutions. We are also ceaselessly investing in quality control.

We provide power systems from 1.1 KV To 400KV such as XLPE cable. Due to rapid industrial and economic it has become necessary to transmit bulk power to sustain growth. It is also very important that while transmitting bulk power, logistics and safety consideration are given due weightage.

At Dicabs, we understand our responsibility and our potential in leading society to remarkable improvements in varied facets of human life and society. For the past

many decades we successfully took the challenge of providing our clients with solutions and support systems to service their global business. We recognize the significance of our customer oriented services for the betterment of society and its operations.

We believe that our responsibility should not end in mere execution of our customer's project but should extend towards contributing our knowledge and expertise in returning value to the company and to the society within which they live. Our vision is to provide world class services and products to our clients with a sense of responsibility and accountability towards them, their employees and ultimately society.

The most ideal solution considering all the aspects is to transmit bulk power through an EHV cable network. Keeping in line with the basic philosophy of the organization, Dicabs is now manufacturing Extra High Voltage cables from 66kV to 550kV.



Salient Features of Hybrid CCV Line Manufacturing Process

The system adopted for triple extrusion of EHV XLPE Cables with dry cure dry cooled process in a Hybrid CCV line ensures the following excellent characteristics:

- The Insulation has no eccentricity.
- The cross-linking of XLPE is of the highest grade with guarantees excellent electro-mechanical characteristics.
- The simultaneous extrusion of inner and outer semi conducting layers and the insulation prevents treeing and other irregularities

- Uniformity of quality is maintained for all products, as the manufacturing processes are controlled.

EHV Cables are manufactured and supplied in accordance to the following applicable standards:

- IEC-62067
- IEC-60840
- IS 7098(Part I | II)

And any other international specifications like ASTM, BS, DIN, JIS etc.

At Diamond Power Infrastructures Ltd. state of the art manufacturing and testing facilities for Extra High Voltage cables up to and including 500 kV are available, which is unique in the country.

	Manufacturing	
Conductor	Compacted circular conductors	Aluminium Up to 1000 sqmm
	Copper	Up to 800 sqmm
	Segmental (Milliken) type circular conductor	
	Aluminium	1200 sqmm and above
	Copper	1000 sqmm and above
Compound Handling and clean room	The material handling system at DPIL ensures ultimate cleanliness and state of the art feeding system. The semi-conducting feeding area is maintained at clean class 10000, whereas the XLPE insulation compound feeding area is maintained at clean class 1000. The gravity feeding system of the compound reduces the inter granular friction.	
Triple Extrusion	The extrusion of semi-conducting conductor screen, XLPE insulation and semi-conducting insulation screen in one operation by triple extrusion through single cross head ensures perfect bonding of all the layers and results in optically smooth interface which removes all possibilities of irregularities and microvoids formation.	
Curing under inert (Nitrogen gas)	The cross linking process under inert atmosphere keeps the insulation absolutely dry which eliminates all chances of electro-mechanical treeing during whole life of the cable.	
	Testing	
High Voltage Test system	The series resonance test system 700 kV/23000 kVA at DPIL test lab is capable of testing long lengths of Extra High Voltage up to 400KV rating at a small input power. This helps in a major saving to its customers in time and money required for extra joints in the cable system.	
Impulse voltage test	The impulse voltage test equipment at DPIL lab is rated 2400 kV 240 kV Jules. The high energy rating of the test equipment can test extra high voltage cable samples up to 400KV rating having very low capacitances.	
Partial discharge test	The shielded room of DPIL cable testing is capable of detecting partial discharges of less than 2 pc.	
Other electrical and physical tests	DPIL cable laboratory is fully equipped to perform all routine, acceptance and type tests for Extra High Voltage cables up to 400 KV rating. As per the requirements of IEC 62067, EC 60840, IS 7098 part-3 and other relevant international specifications.	

Advantages of XLPE

XLPE is an abbreviation of cross-linked polyethylene. This has been recognized world- wide as excellent dielectric material for wires and cables. It first went into commercial production in the 1960. Polyethylene, which is a thermoplastic materials converted into a thermosetting material by a process of cross- linking. The linear chain structure of polyethylene is changed into three-dimensional network structure. By this change, polyethylene, which has outstanding dielectric properties, is made resistant to extreme temperatures. Following are the special advantages of the XLPE cable:

High Continuous Current Ratings:

Higher continuous operating temperature 90°C for conductor permits XLPE cables to carry higher current than PVC or Paper Insulated cables.

High Short Circuit Ratings:

Maximum allowable continuous temperature during short circuit for XLPE insulated cables is 250°C, which increases the short circuit rating of XLPE cables drastically compared to PVC & Paper insulated cables.

Low Deformation at High Temperature:

Under combined heat and mechanical pressure XLPE suffers less deformation compared to other solid dielectrics.

High Emergency Over Load Capacity:

XLPE cables can be operated at 130°C during emergency. This should not exceed 100 Hours in any 12 consecutive months and 500 Hours during the lifetime of the cable.

Low Dielectric Loss:

The dielectric losses of XLPE is much below the conventional solid dielectrics like PVC & EPR. This results in considerable saving in costs when power transmission at higher voltages is done through XLPE cables

Low Charging Currents:

The charging currents are considerably lower than other dielectrics. This permits close setting of protection relays.

The high resistance to heat deformation and ageing in hot air provide an important advantage in cable rating and is of special significance at locations where the ambient temperature is high. These, along with better resistance to environment stress cracking and a low dielectric constant, make XLPE cables particularly suitable for high voltage and extra high voltage applications.

GENERAL PROPERTIES OF EHV XLPE INSULATED CABLES

Specific Gravity	0.93
Tan δ at rated voltage	
1. at ambient temperature (20°C)	10x10 ⁻⁴
2. at operating temperature (90°)	10x10 ⁻⁴
Volume resistivity at 20°C	10 ¹⁷
Max. Permissible operating conductor Temp °C	90°C
Max. Permissible Temp during short circuit °C	250°C
Max. Permissible Temp during short circuit °C	130°C
Dielectric constant at 20°C	2.35

Construction Details of EHV XLPE Cables

The XLPE Cable has the construction of a conductor (copper or aluminium) insulated with cross-linked polyethylene and then shielded with metallic screen (seam welded corrugated aluminium or copper wire shield), to be covered by PVC or polyethylene for anticorrosion followed by a semiconducting layer.

Conductor:

The conductor consists of annealed copper or hard aluminium stranded wires and classified into two major types viz compacted circular and segmental compacted circular (Milliken Conductor).

The compacted circular conductor consists of annealed copper or hard drawn aluminium stranded wires. The Milliken (segmented compacted circular) conductor consists of wires stranded together in segmental form, normally 4- 5 segments and then compacted to get a circular shape. Conductor sizes up to and including 1000 sq. mm. may be compacted circular and 1200 sq. mm. and above size of conductors are made in 4-5 segments. The segmental conductors help in minimizing the increase in AC resistance caused by skin effect and proximity effect.

Conductor Screen:

The conductor screen consists of an extruded semi-conducting polyethylene to minimize electrical stresses due to the stranded configuration of the conductor. The semi- conducting material used for conductor screen has no deleterious effect on the conductor. Semi- conducting tape is generally applied over the conductor before the extruded semi-conducting layer.

Insulation Screen:

The insulation screen is provided over the insulation by extruded semi-conducting compound. This minimizes the possibility of ionization on the outer surface of insulation to make the dielectric stresses radial.

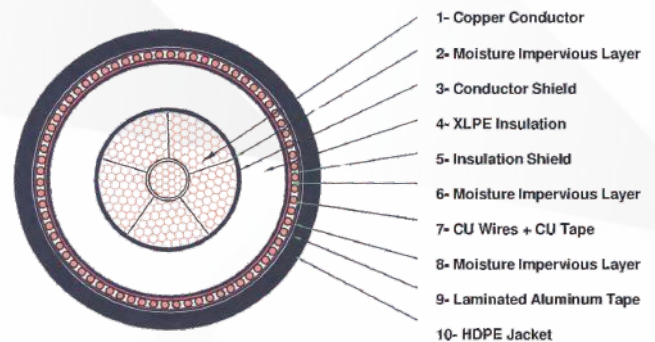

Insulation:

The insulation material is extruded cross-linked polyethylene. The conductor screen, the insulation and the insulation screen are extruded simultaneously in one process (TRIPLE EXTRUSION) to ensure that the screen and insulation are intimately bonded together and free from all possibilities of voids between layers. The extrusion process is carried out under strictly controlled atmospheric conditions. The dry cured & dry cooled process under the inert atmosphere (N₂ Gas) enables to enhance the electromechanical and thermal characteristics of XLPE insulation, which further helps in increasing conductor stress, thereby reducing the thickness of insulation.

Metallic Screen:

The metallic screen consists of wire shield, corrugated aluminium sheath or lead sheath. The lead sheath is provided with or without copper wire screen to withstand the SC rating of screen. The corrugated aluminium sheath and lead sheath also provides a radial moisture barrier to the cable construction.

Outer Sheath:

To protect the metallic sheath from electrical or chemical corrosion, it is covered by PE or PVC sheath.

**66kV 1 core 630 sqmm COMPACTED CIRCULAR ALUMINUM CONDUCTOR
HIGH VOLTAGE CABLE AS PER CUSTOMER SPECIFICATIONS**

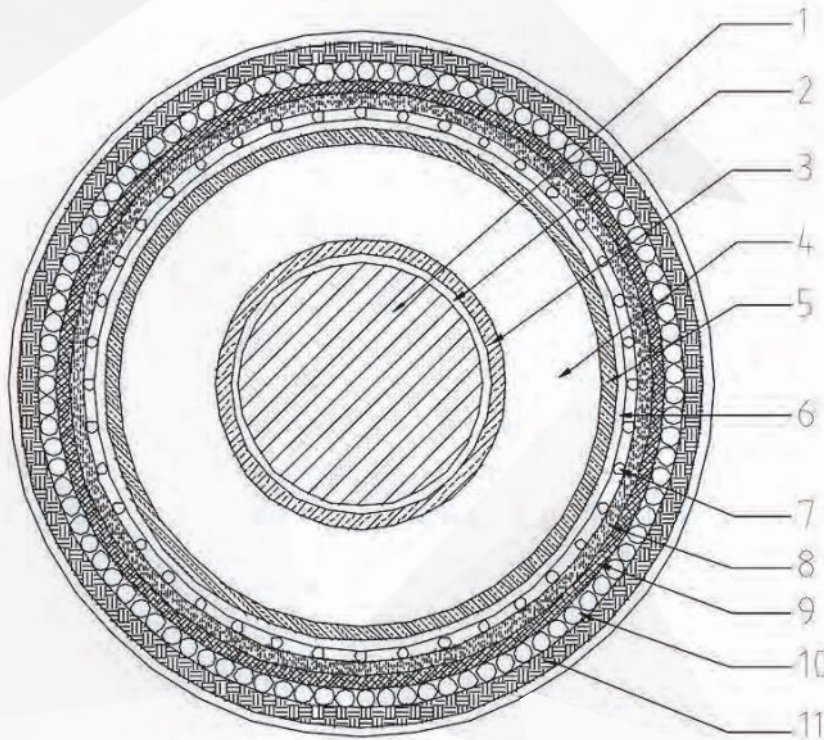

1. Compacted circular Aluminum conductor
2. Semi-conducting tapes
3. Extruded semi conducting thermosetting layer Conductor Screen
4. Cross-linked Polyethylene insulation dry cured
5. Extruded semi conducting thermosetting layer insulation screen
6. Water swellable semi-conducting tapes applied helically with suitable overlap longitudinal water barrier
7. Concentric copper wire screen with open helix copper tape
8. Semi conducting water swellable tape
9. Poly laminated aluminum tape with HDPE inner sheath
10. H.D. Aluminum wire amour
11. PVC outer sheath

**132kV 1 core 800 sqmm compacted circular ALUMINIUM CONDUCTOR
HIGH VOLTAGE CABLE AS PER CUSTOMER SPECIFICATIONS**

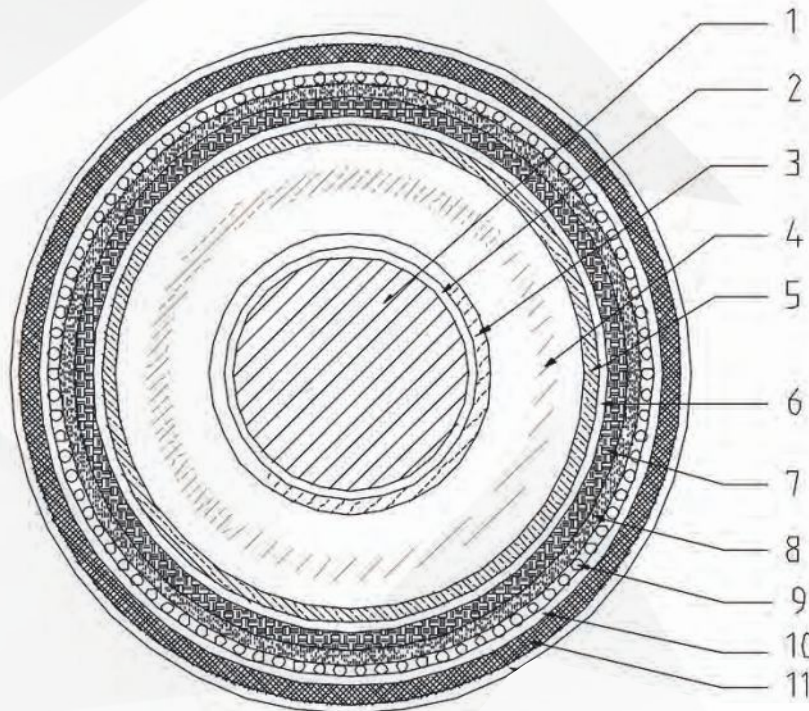

1. Compacted circular copper conductor
2. Semi-conducting tapes
3. Extruded semi conducting thermosetting layer Conductor Screen
4. Cross-linked Polyethylene insulation as per IEC 62067 dry cured
5. Extruded semi conducting thermosetting layer insulation screen
6. Water swellable semi-conducting tapes applied helically with suitable overlap longitudinal water barrier
7. Concentric copper wire screen with open helix copper tape
8. Semi conducting water swellable tape
9. Concentric copper wire screen with open helix copper tape
10. Non conducting water swellable tape
11. PE outer sheath

220kV 1 core 1200 sqmm SEGMENTAL TYPE MILLIKEN COPPER CONDUCTOR EXTRA HIGH VOLATGE CABLE AS PER IEC-62067

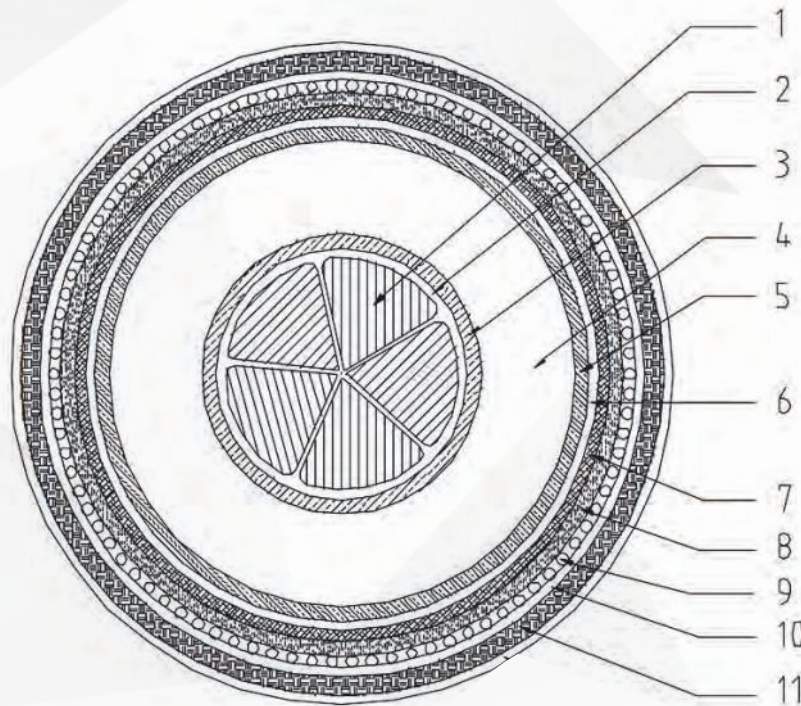

1. Annealed copper segmental milliken conductor
2. Semi-conducting tapes
3. Extruded semi conducting thermosetting layer Conductor Screen
4. Cross-linked Polyethylene insulation as per IEC 62067 dry cured
5. Extruded semi conducting thermosetting layer insulation screen
6. Water swellable semi-conducting tapes applied helically with suitable overlap longitudinal water barrier
7. Lead alloy E Sheath
8. Semi conducting water swellable tape
9. Concentric copper wire screen with open helix copper tape
10. Non conducting water swellable tape
11. PE outer sheath

CONSTRUCTION DETAILS OF DIFFERENT CABLES



Corrugated Aluminium Sheath



Lead Sheath



Copper Wire Shield with Poly Laminated AL Sheath



Copper Wire Shield with Lead Sheath

MANUFACTURING FLOW CHART OF HV/EHV CABLES

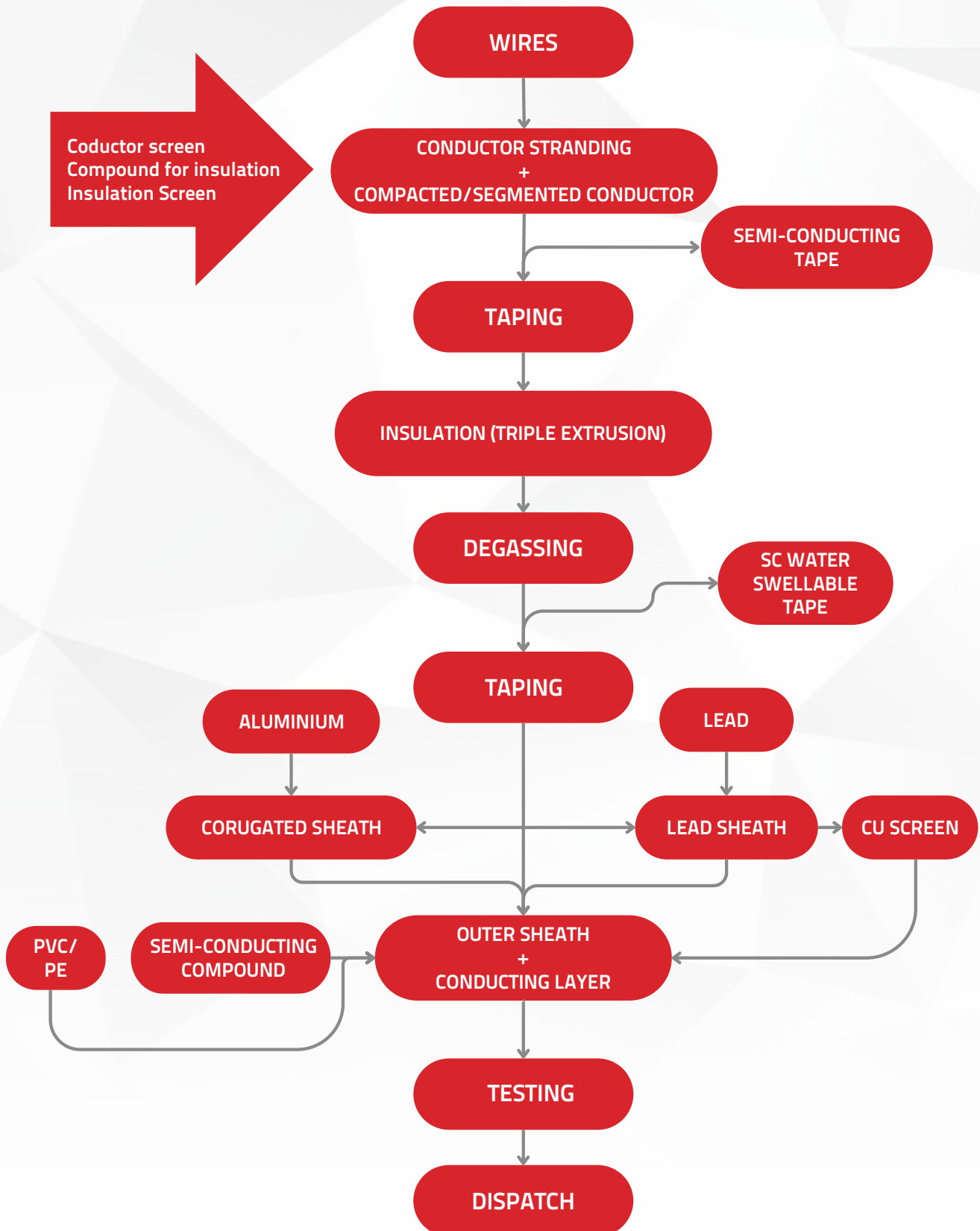

SCHEMATIC DIAGRAM OF CONTINUOUS CATENARY VULCANISATION (CCV) LINE

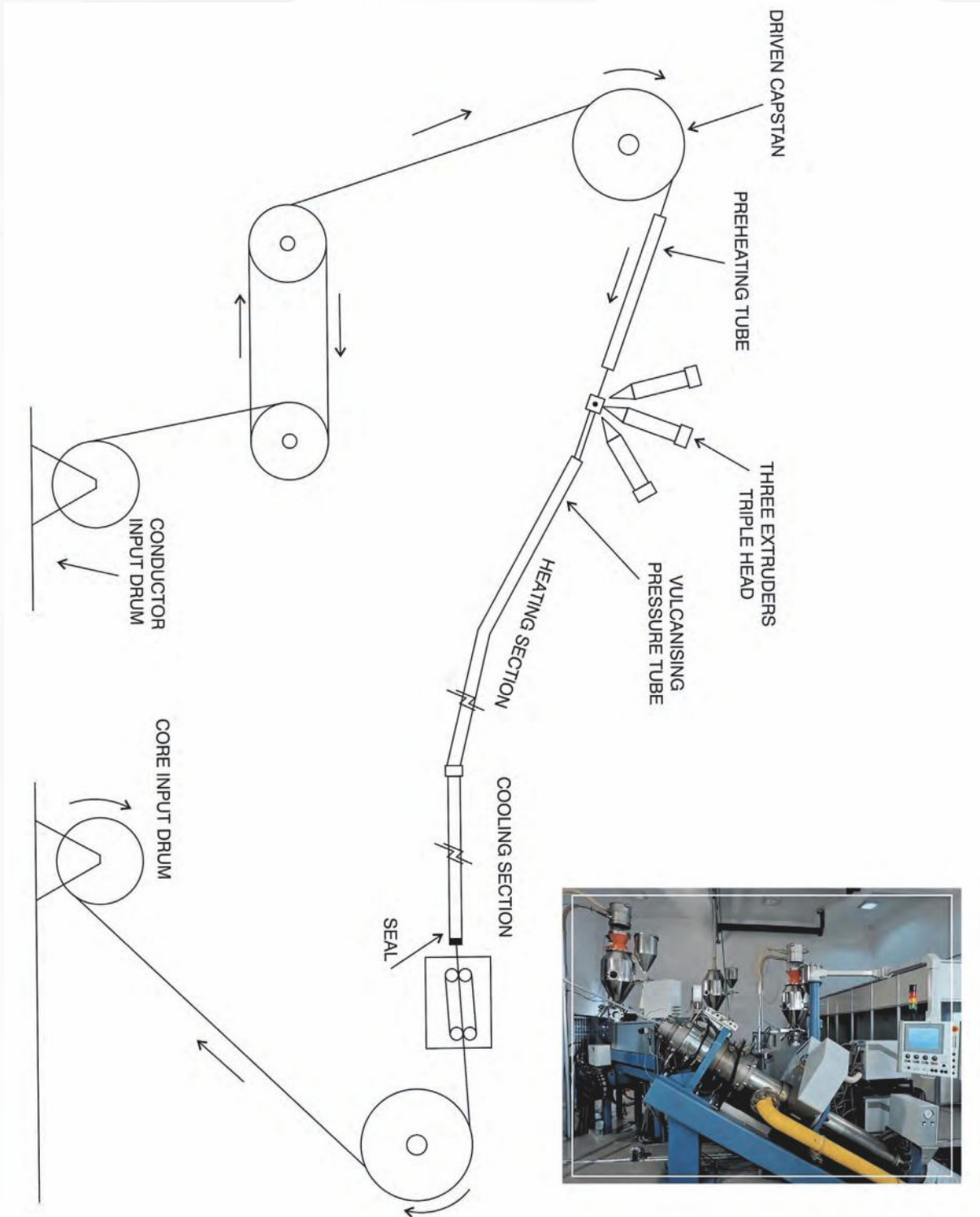

ELECTRICAL TEST PARAMETERS

Voltage Designation U ₀ /U	Highest System voltage U _m	high voltage Test		Partial Discharge Test 1.5U ₀	Impulse Voltage Test kV	Voltage Test After impulse Test	
		Voltage kV	Duration min			kV	Duration Min
38/66	72.5	95	30	57	325	95	15
64/110	123	160	30	96	550	160	15
76/132	145	190	30	114	650	190	15
127/220	245	318	30	190	1050	254	15
220/380	420	440	60	330	1425	440	15
290/500	550	580	60	435	1550	580	15

THICKNESS OF METALLIC SHEATH

General Properties of EHV XLPE insulated cables		Min. Thickness of metallic sheath, mm		
		Lead	Aluminum sheath	
Over	Upto & including		smooth	corrugated
-	40	1.9	1.9	0.6
40	45	2	2.2	0.6
45	50	2.1	2.4	0.6
50	55	2.2	-	0.6
55	60	2.3	-	0.8
60	65	2.4	-	0.8
65	70	2.5	-	0.8
70	75	2.6	-	0.8
75	80	2.7	-	0.8
80	85	2.8	-	0.9
85	90	2.8	-	0.9
90	95	2.9	-	0.9
95	100	3	-	0.9
100	105	3.1	-	1.0
105	110	3.2	-	1.0
110	115	3.3	-	1.0

*Note : Fictitious diameter calculated as described in Annex B of IS 7098 (Part-3)

THICKNESS OF INNER SHEATH

*Calculated Diameter under Inner Sheath mm		Minimum Thickness of Inner Sheath mm
Over	UP to and including	
-		
-	40	0.9
40	45	1.0
45	50	1.1
50	55	1.2
55	60	1.2
60	65	1.3
65	70	1.4
70	75	1.5
75	80	1.6
80	85	1.6
85	90	1.7
90	95	1.8
95	100	1.9
100	105	2.0
105	110	2.0
110	115	2.1
115		2.2

***Note :** Fictitious diameter calculated as described in Annex B of IS 7098 (Part-3)

DIMENSIONS OF ARMOUR ROUND WIRE

*Calculated Diameter under Armour mm		Nominal Diameter of Round Wire mm
Above	UP to and Including	
40	40	2.00
55	55	2.50
70	70	3.15
		4.00

***Note :** Fictitious diameter calculated as described in Annex B of IS 7098 (Part-3)

THICKNESS OF INNER SHEATH EHV CABLE

*Calculated Diameter under Outer Sheath mm		Thickness of Outer Sheath for Unarmoured Cables		Minimum of Outer Sheath for Armoured Cables
Above	UP to and Including	Nominal mm	Minimum mm	mm
	40	2.4	1.72	1.72
40	45	2.6	1.88	1.88
45	50	2.8	2.04	2.04
50	55	3.0	2.20	2.20
55	60	3.2	2.36	2.36
60	65	3.4	2.52	2.52
65	70	3.6	2.68	2.68
70	75	3.8	2.84	2.84
5	-	4.0	3.00	3.00

*Note : Fictitious diameter calculated as described in Annex B of IS 7098 (Part-3)

THICKNESS OF OUTER SHEATH EHV CABLE

*Calculated Diameter under Outer Sheath mm		Thickness of Outer Sheath for Unarmoured Cables		Minimum of Outer Sheath for Armoured Cables
Above	UP to and Including	Nominal mm	Minimum mm	mm
	40	2.4	1.72	1.72
40	45	2.6	1.88	1.88
45	50	2.8	2.04	2.04
50	55	3.0	2.20	2.20
55	60	3.2	2.36	2.36
60	65	3.4	2.52	2.52
65	70	3.6	2.68	2.68
70	75	3.8	2.84	2.84
75	-	4.0	3.00	3.00

*Note : Fictitious diameter calculated as described in Annex B of IS 7098 (Part-3)

RESISTIVITY TEST FOR SEMI-CONDUCTOR LAYER

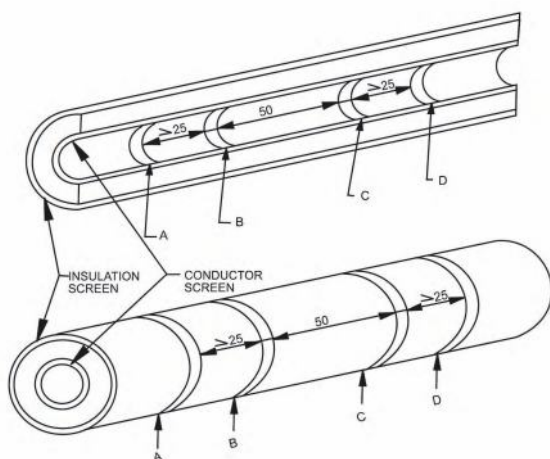

The resistivity test for extruded semiconducting layers applied over the conductor and over the insulation shall be determined by measurements on test pieces taken from core.

The procedure for measurement shall be in accordance with Annex C of IS 7098 (Part-3).

The measurement shall be made at a temperature within $\pm 2^\circ\text{C}$ of the rated maximum normal operating conductor temperature.

The resistivity shall not exceed the following:

Conductor Screen > Core Screen 500 ohm-metre
1000 ohm-metre

ELECTRICAL AND PHYSICAL DIMENSIONS

66 kV (E) Lead Sheathed Cables

Nom. Cross Section of Conduction	Nom. Thickness of insulation	Minimum Lead sheath thickness	Nom. Area of copper screen	Nom. Outer Sheath thickness	Approx. overall cable diameter	Approx. wt. of cable (cu-cond uctor)	Approx. wt. of cable (Al- cond uctor)	Maximum Capacitance	Maximum charging current
(sqmm)	(mm)	(mm)	(sqmm)	(mm)	(mm)	(Kg/m)	(Kg/m)	(μ F/km)	(A/km)
240	9.0	1.8	187	2.7	56	8.5		0.22	2.6
300	9.0	1.8	186	2.7	58	9.2		0.21	2.9
400	9.0	1.9	183	2.8	61	10.5	8.1	0.26	3.1
500	9.0	2.0	180	2.9	64	11.9	8.9	0.28	3.3
630	9.0	2.1	176	3.0	68	13.7	9.9	0.31	3.7
800	9.0	2.2	171	3.2	75	16.3	11.4	0.36	4.3
1000	9.0	2.3	167	3.3	79	18.7	12.6	0.38	4.5
1200	9.0	2.4	162	3.4	84	21.7	14.0	0.42	5.0
1400	9.0	2.5	156	3.5	90	24.5	15.5	0.47	5.6
1600	9.0	2.6	152	3.6	93	27.0	16.6	0.48	5.7
2000	9.0	2.7	145	3.8	99	31.0	18.8	0.53	6.3

*Note : Fault rating Lead in combination with copper screen is 31.5 kA for one second duration

110 kV (E) Lead Sheathed Cables

Nom. Cross Section of Conduction	Nom. Thickness of insulation	Minimum Lead sheath thickness	Nom. Area of copper screen	Nom. Outer Sheath thickness	Approx. overall cable diameter	Approx. wt. of cable (cu-cond uctor)	Approx. wt. of cable (Al- cond uctor)	Maximum Capacitance	Maximum charging current
(sqmm)	(mm)	(mm)	(sqmm)	(mm)	(mm)	(Kg/m)	(Kg/m)	(UF/km)	(A/km)
240	17.0	2.2	172	3.2	73	11.7	-	0.14	2.8
300	15.0	2.2	172	3.2	72	12.0	-	0.16	3.2
400	15.0	2.3	169	3.3	76	13.4	11.1	0.17	3.4
500	15.0	2.4	165	3.4	79	15.0	12.0	0.19	3.8
630	15.0	2.4	163	3.5	82	16.6	12.8	0.21	4.2
800	15.0	2.5	157	3.6	88	19.3	14.4	0.24	4.8
1000	15.0	2.7	150	3.7	93	22.2	16.1	0.25	5.0
1200	15.0	2.8	144	3.8	98	25.3	17.6	0.28	5.6
1400	15.0	2.8	140	4.0	103	28.1	19.1	0.30	6.0
1600	15.0	2.8	138	4.1	106	30.4	20.0	0.32	6.4
2000	15.0	3.0	128	4.3	113	34.9	22.7	0.34	6.8

*Note : Fault rating Lead Sheath in combination with Copper screen is 31.5 kA for one second duration

ELECTRICAL AND PHYSICAL DIMENSIONS

132 kV (E) Lead Sheathed Cables

Nom. Cross Section of Conduction	Nom. Thickness of insulation	Minimum Lead sheath thickness	Nom. Area of copper screen	Nom. Outer Sheath thickness	Approx. overall cable diameter	Approx. wt. of cable (Cu-conductor)	Approx. wt. of cable (Al-conductor)	Maximum Capacitance	Maximum charging current
(sqmm)	(mm)	(mm)	(sqmm)	(mm)	(mm)	(Kg/m)	(Kg/m)	(μ F/km)	(A/km)
240	21.5	2.5	160	3.6	84	14.1	-	0.12	2.9
300	20.5	2.5	160	3.6	84	14.6	-	0.13	3.1
400	19.0	2.5	160	3.6	84	15.2	12.9	0.15	3.6
500	18.0	2.5	160	3.6	85	16.2	13.3	0.17	4.1
630	18.0	2.6	155	3.7	89	18.3	14.5	0.18	4.3
800	17.5	2.7	149	3.8	94	20.9	16.0	0.21	5.0
1000	17.5	2.8	144	3.9	98	23.6	17.5	0.23	5.5
1200	17.5	2.8	141	4.0	103	26.6	18.8	0.25	6.0
1400	17.5	2.9	134	4.1	109	34.4	25.4	0.27	6.4
1600	17.5	3.0	129	4.2	111	32.3	21.9	0.28	6.7
2000	17.5	3.2	118	4.4	118	36.9	24.7	0.30	7.2

*Note : Fault rating Lead Sheath in combination with Copper screen is 31.5 kA for one second duration

220 kV (E) Lead Sheathed Cables

Nom. Cross Section of Conduction	Nom. Thickness of insulation	Minimum Lead sheath thickness	Nom. Area of copper screen	Nom. Outer Sheath thickness	Approx. overall cable diameter	Approx. wt. of cable (Cu-conductor)	Approx. wt. of cable (Al-conductor)	Maximum Capacitance	Maximum charging current
(sqmm)	(mm)	(mm)	(sqmm)	(mm)	(mm)	(Kg/m)	(Kg/m)	(μ F/km)	(A/km)
500	26	2.9	195	4.2	103	22.3	19.4	0.13	5.2
630	25	2.9	193	4.2	105	23.8	20.0	0.15	6.0
800	25	3.0	186	4.4	111	26.9	22.0	0.17	6.8
1000	25	3.2	177	4.5	115	30.1	24.0	0.18	7.2
1200	25	3.3	170	4.6	120	33.7	25.9	0.19	7.6
1400	25	3.4	162	4.7	126	37.1	28.1	0.20	8.0
1600	25	3.4	160	4.8	129	39.5	29.2	0.21	8.0
2000	25	3.6	148	5.0	136	44.6	32.4	0.23	9.2

*Note : Fault rating Lead Sheath in combination with Copper screen is 31.5 kA for one second duration

ELECTRICAL AND PHYSICAL DIMENSIONS

66 kV (E) Corrugated Aluminium Sheathed Cables

Nom. Cross Section of Conduction	Nom. Thickness of insulation	Minimum Aluminium sheath thickness	Nom. Outer Sheath thickness	Approx. overall cable diameter	Approx. wt. of cable (Al-cond uctor)	Approx. wt. of cable (Al-cond uctor)	Maximum Capacitance	Maximum charging current
(sqmm)	(mm)	(mm)	(mm)	(mm)	(Kg/m)	(Kg/m)	(µF/km)	(A/km)
240	9	2.1	2.7	60	4.7	-	0.22	2.6
300	9	2.0	2.8	62	5.4	-	0.24	2.9
400	9	1.9	2.9	65	6.3	4.0	0.26	3.1
500	9	1.8	3.0	68	7.3	4.4	0.28	3.3
630	9	1.7	3.1	72	8.8	5.0	0.31	3.7
800	9	1.7	3.3	80	10.8	5.9	0.36	4.3
1000	9	1.7	3.4	84	12.9	6.8	0.38	4.5
1200	9	1.8	3.5	89	15.4	7.6	0.42	5.0
1400	9	1.9	3.7	97	17.7	8.7	0.47	5.6
1600	9	1.9	3.8	100	19.8	9.4	0.48	5.7
2000	9	2.0	4.0	107	23.2	11.0	0.53	6.3

*Note : Fault rating Aluminium Sheath is 31.5 kA for one second duration

110 kV (E) Corrugated Aluminium Sheathed Cables

Nom. Cross Section of Conduction	Nom. Thickness of insulation	Minimum Aluminium sheath thickness	Nom. Outer Sheath thickness	Approx. overall cable diameter	Approx. wt. of cable (Al-cond uctor)	Approx. wt. of cable (Al-cond uctor)	Maximum Capacitance	Maximum charging current
(sqmm)	(mm)	(mm)	(mm)	(mm)	(Kg/m)	(Kg/m)	(µF/km)	(A/km)
240	17.0	1.7	3.3	79	6.3	-	0.14	2.8
300	15.5	1.7	3.3	78	6.7	-	0.16	3.2
400	15.5	1.7	3.4	81	7.7	5.4	0.17	3.4
500	15.5	1.8	3.5	85	9.0	6.0	0.19	3.8
630	15.0	1.8	3.6	87	10.4	6.6	0.21	4.2
800	15.0	1.9	3.7	94	12.6	7.7	0.24	4.8
1000	15.0	2.0	3.9	100	14.8	8.7	0.25	5.0
1200	15.0	2.0	4.0	105	17.4	9.6	0.28	5.6
1400	15.0	2.1	4.1	111	19.8	10.8	0.3	6.0
1600	15.0	2.2	4.2	114	22.0	11.6	0.32	6.4
2000	15.0	2.3	4.5	122	25.6	13.4	0.34	6.8

*Note : Fault rating Aluminium Sheath is 31.5 kA for one second duration

ELECTRICAL AND PHYSICAL DIMENSIONS

110 kV (E) Corrugated Aluminium Sheathed Cables

Nom. Cross Section of Conduction	Nom. Thickness of insulation	Minimum Aluminum sheath thickness	Nom. Outer Sheath thickness	Approx. overall cable diameter	Approx. wt. of cable (Al-cond uctor)	Approx. wt. of cable (Al-cond uctor)	Maximum Capacitance	Maximum charging current
(sqmm)	(mm)	(mm)	(mm)	(mm)	(Kg/m)	(Kg/m)	(μ F/km)	(A/km)
240	21.5	1.9	3.6	89	7.7	-	0.12	2.9
300	20.5	1.9	3.6	89	8.1	-	0.13	3.1
400	19.5	1.9	3.6	89	8.8	6.4	0.15	3.6
500	18.5	1.9	3.7	90	9.7	6.8	0.17	4.1
630	18.0	1.9	3.8	94	11.4	7.5	0.18	4.3
800	17.5	2.0	3.9	101	13.4	8.6	0.21	5.0
1000	17.5	2.1	4.1	105	15.7	9.6	0.23	5.5
1200	17.5	2.1	4.2	111	18.3	10.6	0.25	6.0
1400	17.5	2.2	4.4	119	20.8	11.8	0.27	6.4
1600	17.5	2.3	4.5	121	23.1	12.7	0.28	6.7
2000	17.5	2.4	4.7	128	26.7	14.5	0.30	7.2

*Note : Fault rating Aluminium Sheath is 31.5 kA for one second duration

220 kV (E) Corrugated Aluminium Sheathed Cables

Nom. Cross Section of Conduction	Nom. Thickness of insulation	Minimum Aluminum sheath thickness	Nom. Outer Sheath thickness	Approx. overall cable diameter	Approx. wt. of cable (Al-cond uctor)	Approx. wt. of cable (Al-cond uctor)	Maximum Capacitance	Maximum charging current
(sqmm)	(mm)	(mm)	(mm)	(mm)	(Kg/m)	(Kg/m)	(μ F/km)	(A/km)
500	26	2.2	4.3	110	12.5	9.6	0.13	5.2
630	25	2.2	4.3	112	13.9	10.0	0.15	6.0
800	25	2.3	4.6	120	16.3	11.5	0.17	6.8
1000	25	2.4	4.7	124	18.7	12.6	0.18	7.2
1200	25	2.4	4.8	129	21.4	13.7	0.19	7.6
1400	25	2.5	5.0	138	24.1	15.1	0.20	8.0
1600	25	2.6	5.1	140	26.4	16.1	0.21	8.4
2000	25	2.7	5.3	147	30.2	18.1	0.23	9.2

*Note : Fault rating Aluminium Sheath is 40 kA for one second duration

*Note : Construction Data given in above tables are for guidance only. Cables as per National (IS 7098 - Part 3)/International specifications IEC 62067, IEC 60502, IEC 60840 shall be offered on request.

Assumption for Calculation of CONTINUOUS CURRENT RATING as per IEC 60287. The continuous current carrying capacity of XLPE cables is calculated as per the following standard conditions :

1. Ground Temperature	:30°C
2. Ambient Air Temperature	:40°C
3. Max. Conductor Temperature	:90°C
4. Depth of laying	:1.0Mtr
5. Soil Thermal Resistivity	:150°C-cm/W
6. Soil Thermal Resistivity	:Trefoil Touching with single point or cross bonding OR Flat
7. Cable Installation Formation with bonding	:70mm clearance (Surface to surface) single point or Cross
8. Frequency	:50Hz
9. Load Factor	:100%

Maximum Permissible Conductor Temperature and Recommended conductor temperatures for various conditions are as under:

1. Normal Operation	:90°C
2. Emergency Operation	:130°C
3. Short Circuit	:250°C



CONDUCTOR RESISTANCE

Cross Sectional area of Conductor sq.mm.	DC Resistance of Conductor at 20°C		AC Resistance of Conductor at 20°C	
	AL Ω/km	CU Ω/km	CU Ω/km	CU Ω/km
95	0.3200	0.1930	0.4110	0.2460
120	0.2530	0.1530	0.3250	0.1960
150	0.2060	0.1240	0.2640	0.1590
185	0.1640	0.0991	0.2110	0.1270
240	0.1250	0.0754	0.1610	0.0972
300	0.1000	0.0601	0.1290	0.0780
400	0.0778	0.0470	0.1010	0.0618
500	0.0605	0.0366	0.0791	0.0491
630	0.0469	0.0283	0.0622	0.0393
800	0.0367	0.0221	0.0497	0.0322
1000	0.0291	0.0176	0.0380	0.0236
1200	0.0247	0.0151	0.0326	0.0207
1600	0.0186	0.0113	0.0251	0.0163

CONDUCTOR SHORT CIRCUIT RATING

Cross Sectional area of Conductor sq.mm.	Short Circuit Rating (1 sec)	
	AL KA	CU KA
95	8.9	13.6
120	11.3	17.2
150	14.1	21.5
185	17.4	26.5
240	22.6	34.3
300	28.2	42.9
400	37.6	57.2
500	47.0	71.5
630	59.2	90.1
800	75.2	114.4
1000	94.0	143.0
1200	112.8	171.6
1600	150.4	228.8
2000	188.0	286.0

CONDUCTOR RESISTANCE

Cross Sectional Area of conductor	Single Point Bonding / Cross Bonding							
	Trefoil Formation				Flat Formation			
	In Ground		In Air		In Ground		In Air	
Sq mm	Aluminium Amp	Copper Amp	Aluminium Amp	Copper Amp	Aluminium Amp	Copper Amp	Aluminium Amp	Copper Amp
95	194	250	271	349	202	261	295	380
120	221	383	312	401	230	296	341	438
150	246	316	352	452	257	331	385	496
185	277	354	402	515	290	372	440	566
240	319	407	471	602	335	429	519	666
300	358	455	537	685	377	483	594	762
400	408	513	624	789	431	548	692	882
500	462	576	722	904	491	620	806	1021
630	523	644	835	1033	560	701	938	1179
800	585	708	953	1161	632	781	1080	1341
1000	686	816	1111	1372	723	905	1264	1592
1200	722	871	1235	1503	790	977	1416	1763
1600	815	965	1434	1716	907	1108	1669	2055
2000	892	1038	1613	1897	1008	1216	1904	2317

CURRENT RATING OF SINGLE CORE 66KV CABLE

Cross Sectional Area of conductor	Both End Bonding							
	Trefoil Formation				Flat Formation			
	In Ground		In Air		In Ground		In Air	
Sq mm	Aluminium Amp	Copper Amp	Aluminium Amp	Copper Amp	Aluminium Amp	Copper Amp	Aluminium Amp	Copper Amp
95	191	242	267	341	189	234	284	357
120	215	272	307	390	211	258	324	404
150	239	301	345	437	231	281	362	449
185	267	334	391	494	255	305	408	501
240	305	378	456	571	284	335	469	570
300	339	417	516	642	309	359	524	629
400	80	461	593	728	337	384	591	697
500	424	507	678	821	365	407	662	767
630	471	554	772	920	391	429	737	837
800	516	595	866	1013	415	447	806	900
1000	554	631	961	1115	437	465	884	976
1200	587	660	1048	1198	453	477	946	1032
1600	639	704	1176	1317	474	493	1030	1105
2000	678	736	1285	1415	490	505	1101	1166

CURRENT RATING OF SINGLE CORE 110/ 132 KV CABLE

Cross Sectional Area of conductor	Single Point boning / Cross Bonding							
	Trefoil Formation				Flat Formation			
	In Ground		In Air		In Ground		In Air	
Sq mm	Aluminium Amp	Copper Amp	Aluminium Amp	Copper Amp	Aluminium Amp	Copper Amp	Aluminium Amp	Copper Amp
185	277	354	398	510	289	371	429	551
240	319	407	467	598	335	429	505	649
300	358	456	533	680	377	483	578	742
400	408	514	618	783	431	548	673	859
500	463	577	715	898	491	620	783	992
630	523	646	826	1027	560	701	910	1145
800	586	712	943	1155	632	782	1046	1302
1000	666	817	1098	1362	723	905	1223	1544
1200	721	873	1219	1492	789	977	1368	1708
1600	816	969	1417	1707	906	1108	1612	1992
2000	893	1043	1595	1890	1007	1217	1838	2247

CURRENT RATING OF SINGLE CORE 66KV CABLE

Cross Sectional Area of conductor	Single Point boning / Cross Bonding							
	Trefoil Formation				Flat Formation			
	In Ground		In Air		In Ground		In Air	
Sq mm	Aluminium Amp	Copper Amp	Aluminium Amp	Copper Amp	Aluminium Amp	Copper Amp	Aluminium Amp	Copper Amp
185	268	336	390	494	256	308	403	499
240	306	381	455	574	286	338	465	570
300	341	421	516	646	312	363	521	632
400	383	466	593	735	341	389	591	705
500	428	513	679	830	369	414	664	778
630	475	561	775	933	396	436	741	853
800	522	605	871	1030	420	454	815	920
1000	559	639	970	1138	443	473	897	1003
1200	593	668	1057	1222	459	485	961	1060
1600	645	713	1190	1347	480	500	1050	1137
2000	685	746	1303	1449	496	512	1123	1200

CURRENT RATING OF SINGLE CORE 220 KV CABLE

Cross Sectional Area of conductor	Single Point boning / Cross Bonding							
	Trefoil Formation				Flat Formation			
	In Ground		In Air		In Ground		In Air	
Sq mm	Aluminium Amp	Copper Amp	Aluminium Amp	Copper Amp	Aluminium Amp	Copper Amp	Aluminium Amp	Copper Amp
400	406	513	608	771	430	546	651	831
500	461	576	703	885	490	619	756	960
630	522	645	811	1212	558	699	878	1106
800	585	712	927	1141	630	780	1009	1258
1000	664	815	1077	1342	720	902	1178	1490
1200	728	870	1195	1470	785	973	1316	1647
1600	809	961	1386	1678	899	1101	1546	1916
2000	896	1010	1544	1833	990	1191	1756	2147

CURRENT RATING OF SINGLE CORE 220KV CABLE

Cross Sectional Area of conductor	Both End Bonding							
	Trefoil Formation				Flat Formation			
	In Ground		In Air		In Ground		In Air	
Sq mm	Aluminium Amp	Copper Amp	Aluminium Amp	Copper Amp	Aluminium Amp	Copper Amp	Aluminium Amp	Copper Amp
400	384	469	589	734	344	394	585	706
500	429	518	674	831	373	419	660	784
630	478	566	770	935	400	442	740	862
800	525	612	869	1038	425	461	818	935
1000	562	646	971	1152	448	480	904	1024
1200	595	674	1059	1237	465	493	971	1085
1600	643	713	1188	1358	493	516	1071	1174
2000	670	728	1286	1440	537	561	1186	1288

Rating factor for Variation in ambient air temperature :

Air temperature °C conductor temp 90°C Rating factors	15	20	25	30	35	40	45	50	55	60
	1.25	1.20	1.16	1.11	1.05	1.00	0.94	0.88	0.82	0.76

Rating factor for Variation in ground temperature:

Air temperature °C conductor temp 90°C Rating factors	15	20	25	30	35	40	45	50
	1.12	1.08	1.04	1	0.96	0.91	0.87	0.82

Rating factor for grouping of single core laid direct in ground in horizontal formation:

Distance between Centres of Circuits					Distance between Centres of Circuits					
mm	1	2	3	4	5	6	7	8	9	
120	1	0.76	0.67	0.59	0.55	0.51	0.49	0.47	0.46	
200	1	0.81	0.71	0.65	0.61	0.58	0.56	0.53	0.52	
400	1	0.85	0.77	0.72	0.69	0.66	0.64	0.63	0.62	
600	1	0.88	0.81	0.77	0.74	0.72	0.71	0.70	0.69	
800	1	0.90	0.84	0.81	0.79	0.77	0.76	0.75	0.75	
2000	1	0.96	0.93	0.92	0.91	0.91	0.91	0.90	0.90	

Rating factor for thermal resistivity of soil :

Soil thermal resistivity Deg. C cm/watt	70	100	120	150	200	250	300
Rating factor	1.36	1.19	1.11	1.00	0.88	0.78	0.73

Rating factor for depth of laying :

Depth of laying cm	90	100	120	150	160	170	180	190	200
Rating factor	1.06	1.05	1.03	1.00	0.99	0.99	0.98	0.98	0.97

Rating factor for phase spacing in flat formation :

Phase Spacing (s) cm	D	D+70	D+200	D+250	D+300	D+350	D+400
Rating factor	0.93	1.00	1.03	1.05	1.07	1.08	1.10

Note : D is the overall diameter of cable

GROUP RATING FACTORS

Group rating factors for cables aid in formed concrete trenches with removable cover on cable troughs where air circulation is restricted. The cables spaced by one cable diameter and trays in tiers by 300 mm. The clearance of the cable from the wall is 20mm.

No. of troughs	No. of Group (circuits)		
	1	2	3
1	0.92	0.89	0.88
2	0.87	0.84	0.83
3	0.84	0.82	0.81
4	0.82	0.80	0.79

Group rating factors for cables laid on racks. The cables spaced by one cable diameter and racks in tiers by 300mm, the between the wall and the cables is 20 mm.

No. of troughs	No. of Group (circuits)		
	1	2	3
1	1.0	0.97	0.96
2	0.97	0.94	0.93
3	0.96	0.93	0.92
6	0.94	0.91	0.90

INSTALLATION

A. Underground Installation of EHV XLPE Cables

1.1 Bending Radius The minimum bending radius for EHV XLPE cable is $20xD$, where D is the overall diameter of the cable.

1.2 Installation in ground Underground XLPE cables are usually buried directly in the ground. Single core cables can be laid in flat or trefoil formation as shown in figures.

THREE SINGLE CORE CABLES IN TREFOIL FORMATION

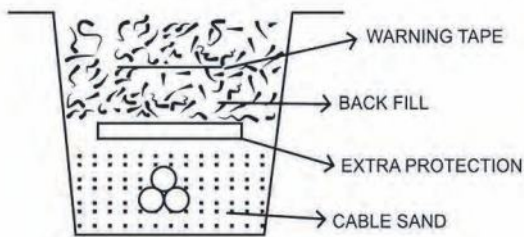

THREE SINGLE CORE CABLES IN FLAT FORMATION

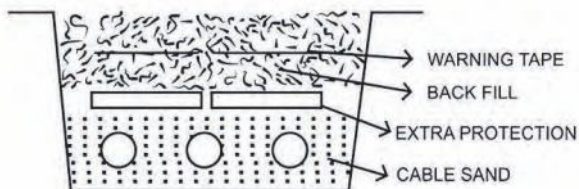

1.3 Depth of laying - As a general rule EHV cables are laid at a depth of 1 to 1.5 m. The laying depth is chosen depending on obstacles in the ground e.g. telephone cables or water pipes. There may be reasons for deeper laying, which then means a reduction of current carrying capacity.

1.4 Sand bedding - The cable shall be completely surrounded by well compacted sand to such a thickness and of such a grain size that the cable is protected against damage. The thickness of the sand bedding should normally be a minimum of 10 cm in all directions from the cable surface. Sand with a grain size less than 8 mm is considered to give the cable a good protection.

1.5 Extra protection Important feeders and cables at places where extended digging activity is expected can be further protected against damage by means of tubes, slabs, troughs or warning tapes. Ducts of non-magnetic material for single core cables can be mainly used at road crossing etc. The duct diameter should not be less than 1.5 times the cable diameter.

SINGLE CORE CABLES IN PROTECTING DUCTS, FLAT FORMATION

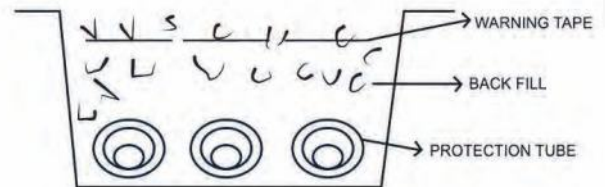

In trenches normally extra protection is obtained by means of concrete slabs and its size is to be chosen according to the expected damage. The slabs are placed directly on the cable sand.

1.6 Back filling - Normally, the back fill consists of the material earlier excavated. However, bigger stones or pieces of rock should be removed.

1.7 Warning Tape - A pre-warning tape, e.g. of yellow PVC tape should be laid in the ground.

1.8 Transportation - In order to avoid damage to the cable, the cable drum must be handled carefully during transportation. It is very important that the cable drum stands on the flanges during transportation, well fixed to the transport vehicle. Loading and unloading should be made by crane or fork-truck, not by rolling.

Rolling of the drum should be done slowly and carefully in the direction of the arrow on the drum flange.

1.9 Cable Pulling - During the pulling, the cable drum is normally placed on jacks at the starting point and a wire winch at the other end of the trench. The pulling wire can be connected to the cable either by a cable stocking or pulling eye to the conductor in such a manner that water or soil can not enter into the cable.

The pulling force should be restricted to the following values

- For aluminium conductor 30 N/sqmm
- For copper conductor 50 N/sqmm

The cable should preferably be pulled from the top of the drum.

To prevent crossing of turns on the drum at a sudden pulling stop, a brake should be arranged at the cable drum and a man placed there to operate this brake, which must be applied rapidly at a stop.

To protect the cable from damage during the pulling out, cable rollers should be used and placed at suitable intervals. At bends, angle rollers & guide rollers as required must be used in order to maintain the desired bending radius of the cable.

During the cable pulling, telephones or walkietalkie should be used to ensure the internal communication is established in order to prevent accidents and to enable a safe pulling operation.

B) Installation of XLPE cable in air The requirement for bending radii, transportation and pulling of the cables are the same as for underground installation. For fixing of the cables, the following has to be taken into consideration.

Cable Fixing	After laying of three Nos cables, the cable shall be tied up with non-magnetic metals trefoil/single clamp depending upon the laying configurations ie. trefoil/flat.
Horizontal Distance between cleats	At 1 to 1.2 meter interval or as per customer's choice.
Vertical distance between cleats	If the cable circuits are laid in tiers then the vertical spacing between the tiers shall not be less than 300mm.



SCREEN BONDING METHOD

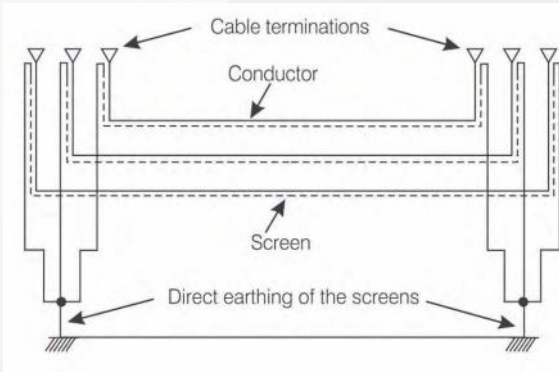

Both-ends bonding of screens, means that the screens are connected and earthed at both ends of the cable route. In this case a current will appear in the screen. This will cause losses in the screen, which reduces the cable current-carrying capacity. These losses are smaller for cables in trefoil formation than in flat formation.

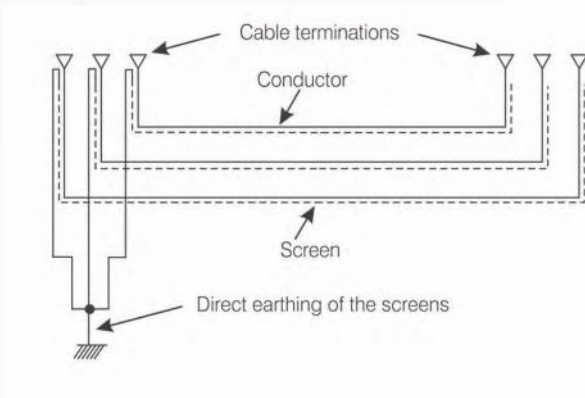

Single-point bonding of screens, means that the screens are connected and earthed at one end of the cable route. In this case, no voltage will be induced between screen and earth, but no current will appear. This induced voltage is proportional to the cable length and current. Single-point bonding can only be used for limited route lengths.

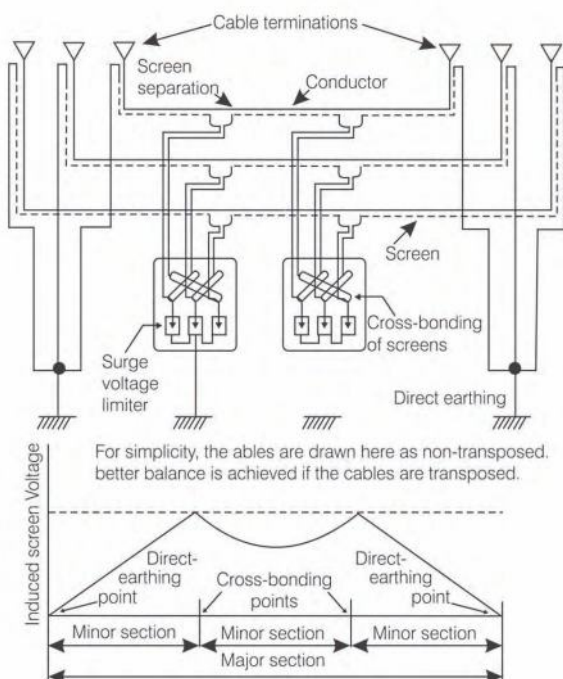

Cross-bonding of screens, means that the screens belonging to adjoining cables are connected as in the figure. In this case, a voltage will be induced between screen and earth, but no current will appear. The maximum induced voltage will appear at the link boxes for cross-bonding, see figure. This method permits a cable current-carrying capacity as high as with single-point bonding but longer route lengths than the latter. It requires screen separation and additional link boxes.

CERTIFICATE OF REGISTRATION

TUVINDIA

Certificate

Management system as per
ISO 9001:2015

The Certification Body TUV INDIA PVT. LTD. hereby certifies as a result of the audit, assessment and/or surveillance activities according to ISO 9001:2015, that the organization:

DIAMOND POWER INFRASTRUCTURE LTD
Survey No. 88-CP, At Village: Vadodra,
Jarod - Barliya Road, Tal. Sevli,
Dist. Vadodra - 391520,
Gujarat,
India

DICABS
Cable | Conductor | Tower

Design, Development, Manufacture and Marketing of Distribution and Transmission Conductors, LT Power and Control Cables upto 1.1 KV, HV/ EHV XLPE Cables upto 220 KV, Manufacture of Aluminium and Aluminium Alloy Wire Ropes,
Certificate Registration No. 82118-2018-0204-0001 Valid until: 04.09.2020
Each Report No. G 028602023 Initial certificate no.08080003

Mention: 18.09.2018

TUV INDIA PVT. LTD.
871, Ramana Plaza, 1, 153 Main,
Madhavpet, WF Number - 600036,
India.
www.tuvindia.com/india

TUVNORD GROUP

TUVINDIA

Certificate

Management system as per
ISO 45001:2018

The Certification Body TUV INDIA PVT. LTD. hereby certifies as a result of the audit, assessment and/or surveillance activities according to ISO 45001:2018, that the organization:

DIAMOND POWER INFRASTRUCTURE LTD
Survey No. 88-CP, At Village: Vadodra,
Jarod - Barliya Road, Tal. Sevli,
Dist. Vadodra - 391520,
Gujarat,
India

DICABS
Cable | Conductor | Tower

Design, Development, Manufacture and Marketing of Distribution and Transmission Conductors, LT Power and Control Cables upto 1.1 KV, HV/ EHV XLPE Cables upto 220 KV, Manufacture of Aluminium and Aluminium Alloy Wire Ropes,
Certificate Registration No. 82118-2018-0204-0001 Valid until: 04.09.2020
Each Report No. G 028602023 Initial certificate no.08080003

Mention: 18.09.2018

TUV INDIA PVT. LTD.
871, Ramana Plaza, 1, 153 Main,
Madhavpet, WF Number - 600036,
India.
www.tuvindia.com/india

TUVNORD GROUP

TUVINDIA

Certificate

Management system as per
ISO 14001:2015

The Certification Body TUV INDIA PVT. LTD. hereby certifies as a result of the audit, assessment and/or surveillance activities according to ISO 14001:2015, that the organization:

DIAMOND POWER INFRASTRUCTURE LTD
Survey No. 88-CP, At Village: Vadodra,
Jarod - Barliya Road, Tal. Sevli,
Dist. Vadodra - 391520,
Gujarat,
India

DICABS
Cable | Conductor | Tower

Design, Development, Manufacture and Marketing of Distribution and Transmission Conductors, LT Power and Control Cables upto 1.1 KV, HV/ EHV XLPE Cables upto 220 KV, Manufacture of Aluminium and Aluminium Alloy Wire Ropes,
Certificate Registration No. 82118-2018-0204-0001 Valid until: 04.09.2020
Each Report No. G 028602023 Initial certificate no.08080003

Mention: 18.09.2018

TUV INDIA PVT. LTD.
871, Ramana Plaza, 1, 153 Main,
Madhavpet, WF Number - 600036,
India.
www.tuvindia.com/india

TUVNORD GROUP

NABL
National Accreditation Board for
Testing and Calibration Laboratories

CERTIFICATE OF ACCREDITATION

DICABS ELECTRICAL AND PHYSICAL TEST LABORATORIES FOR CABLES AND CONDUCTORS
has been assessed and accredited in accordance with the standard
ISO/IEC 17025:2017
"General Requirements for the Competence of Testing & Calibration Laboratories"
for its facilities at
PHASE - II, BLOCK No. 181 F, 181 P, VILLAGE: VADODRA, JAROD/SAMLA ROAD, TAL. SVELI, VADODRA, GUJARAT, INDIA

Certificate Number: TC-1847
Issue Date: 06/11/2014 Valid Until: 07/11/2025

This certificate remains valid for the Scope of Accreditation as specified in the annexure subject to continued satisfactory compliance to the above standard & the relevant requirements of NABL.
(To see the scope of accreditation of laboratories, you may also visit NABL website www.nabl.org)

Name of Legal Entity: Diamond Power Infrastructure Limited
Signed for and on behalf of NABL

N. Venkateswaran
Chief Executive Officer

TEST REPORT

SABS
High Voltage Laboratory
Survey No. 82/10/2002
Page: 1 of 2

Client: Diamond Power Infrastructure Limited
E-mail: info@dpil.com, Vadodra - 390119
Manufacturer: Diamond Power Infrastructure Limited, India
Approved model: IEC 60227 (single conductor XLPE up to 110 kV)
Voltage rating: 110 kV
Configuration type: Single conductor
Sample identification: 400-100

Tests performed: - Dry RVV and Corona tests

Tests have been carried out in accordance with the client's instructions.

Test procedures and test parameters were based on:
- IEC 60227:2010
- IEC 60270:2010
- IEC 60509:2010
- IEC 60840:2010
- IEC 60853:2010
- IEC 60871:2010
- IEC 60879:2010
- IEC 60894:2010
- IEC 60900:2010
- IEC 60949:2010
- IEC 61089:2010
- IEC 61090:2010
- IEC 61091:2010
- IEC 61092:2010
- IEC 61093:2010
- IEC 61094:2010
- IEC 61095:2010
- IEC 61096:2010
- IEC 61097:2010
- IEC 61098:2010
- IEC 61099:2010
- IEC 61100:2010
- IEC 61101:2010
- IEC 61102:2010
- IEC 61103:2010
- IEC 61104:2010
- IEC 61105:2010
- IEC 61106:2010
- IEC 61107:2010
- IEC 61108:2010
- IEC 61109:2010
- IEC 61110:2010
- IEC 61111:2010
- IEC 61112:2010
- IEC 61113:2010
- IEC 61114:2010
- IEC 61115:2010
- IEC 61116:2010
- IEC 61117:2010
- IEC 61118:2010
- IEC 61119:2010
- IEC 61120:2010
- IEC 61121:2010
- IEC 61122:2010
- IEC 61123:2010
- IEC 61124:2010
- IEC 61125:2010
- IEC 61126:2010
- IEC 61127:2010
- IEC 61128:2010
- IEC 61129:2010
- IEC 61130:2010
- IEC 61131:2010
- IEC 61132:2010
- IEC 61133:2010
- IEC 61134:2010
- IEC 61135:2010
- IEC 61136:2010
- IEC 61137:2010
- IEC 61138:2010
- IEC 61139:2010
- IEC 61140:2010
- IEC 61141:2010
- IEC 61142:2010
- IEC 61143:2010
- IEC 61144:2010
- IEC 61145:2010
- IEC 61146:2010
- IEC 61147:2010
- IEC 61148:2010
- IEC 61149:2010
- IEC 61150:2010
- IEC 61151:2010
- IEC 61152:2010
- IEC 61153:2010
- IEC 61154:2010
- IEC 61155:2010
- IEC 61156:2010
- IEC 61157:2010
- IEC 61158:2010
- IEC 61159:2010
- IEC 61160:2010
- IEC 61161:2010
- IEC 61162:2010
- IEC 61163:2010
- IEC 61164:2010
- IEC 61165:2010
- IEC 61166:2010
- IEC 61167:2010
- IEC 61168:2010
- IEC 61169:2010
- IEC 61170:2010
- IEC 61171:2010
- IEC 61172:2010
- IEC 61173:2010
- IEC 61174:2010
- IEC 61175:2010
- IEC 61176:2010
- IEC 61177:2010
- IEC 61178:2010
- IEC 61179:2010
- IEC 61180:2010
- IEC 61181:2010
- IEC 61182:2010
- IEC 61183:2010
- IEC 61184:2010
- IEC 61185:2010
- IEC 61186:2010
- IEC 61187:2010
- IEC 61188:2010
- IEC 61189:2010
- IEC 61190:2010
- IEC 61191:2010
- IEC 61192:2010
- IEC 61193:2010
- IEC 61194:2010
- IEC 61195:2010
- IEC 61196:2010
- IEC 61197:2010
- IEC 61198:2010
- IEC 61199:2010
- IEC 61200:2010
- IEC 61201:2010
- IEC 61202:2010
- IEC 61203:2010
- IEC 61204:2010
- IEC 61205:2010
- IEC 61206:2010
- IEC 61207:2010
- IEC 61208:2010
- IEC 61209:2010
- IEC 61210:2010
- IEC 61211:2010
- IEC 61212:2010
- IEC 61213:2010
- IEC 61214:2010
- IEC 61215:2010
- IEC 61216:2010
- IEC 61217:2010
- IEC 61218:2010
- IEC 61219:2010
- IEC 61220:2010
- IEC 61221:2010
- IEC 61222:2010
- IEC 61223:2010
- IEC 61224:2010
- IEC 61225:2010
- IEC 61226:2010
- IEC 61227:2010
- IEC 61228:2010
- IEC 61229:2010
- IEC 61230:2010
- IEC 61231:2010
- IEC 61232:2010
- IEC 61233:2010
- IEC 61234:2010
- IEC 61235:2010
- IEC 61236:2010
- IEC 61237:2010
- IEC 61238:2010
- IEC 61239:2010
- IEC 61240:2010
- IEC 61241:2010
- IEC 61242:2010
- IEC 61243:2010
- IEC 61244:2010
- IEC 61245:2010
- IEC 61246:2010
- IEC 61247:2010
- IEC 61248:2010
- IEC 61249:2010
- IEC 61250:2010
- IEC 61251:2010
- IEC 61252:2010
- IEC 61253:2010
- IEC 61254:2010
- IEC 61255:2010
- IEC 61256:2010
- IEC 61257:2010
- IEC 61258:2010
- IEC 61259:2010
- IEC 61260:2010
- IEC 61261:2010
- IEC 61262:2010
- IEC 61263:2010
- IEC 61264:2010
- IEC 61265:2010
- IEC 61266:2010
- IEC 61267:2010
- IEC 61268:2010
- IEC 61269:2010
- IEC 61270:2010
- IEC 61271:2010
- IEC 61272:2010
- IEC 61273:2010
- IEC 61274:2010
- IEC 61275:2010
- IEC 61276:2010
- IEC 61277:2010
- IEC 61278:2010
- IEC 61279:2010
- IEC 61280:2010
- IEC 61281:2010
- IEC 61282:2010
- IEC 61283:2010
- IEC 61284:2010
- IEC 61285:2010
- IEC 61286:2010
- IEC 61287:2010
- IEC 61288:2010
- IEC 61289:2010
- IEC 61290:2010
- IEC 61291:2010
- IEC 61292:2010
- IEC 61293:2010
- IEC 61294:2010
- IEC 61295:2010
- IEC 61296:2010
- IEC 61297:2010
- IEC 61298:2010
- IEC 61299:2010
- IEC 61300:2010
- IEC 61301:2010
- IEC 61302:2010
- IEC 61303:2010
- IEC 61304:2010
- IEC 61305:2010
- IEC 61306:2010
- IEC 61307:2010
- IEC 61308:2010
- IEC 61309:2010
- IEC 61310:2010
- IEC 61311:2010
- IEC 61312:2010
- IEC 61313:2010
- IEC 61314:2010
- IEC 61315:2010
- IEC 61316:2010
- IEC 61317:2010
- IEC 61318:2010
- IEC 61319:2010
- IEC 61320:2010
- IEC 61321:2010
- IEC 61322:2010
- IEC 61323:2010
- IEC 61324:2010
- IEC 61325:2010
- IEC 61326:2010
- IEC 61327:2010
- IEC 61328:2010
- IEC 61329:2010
- IEC 61330:2010
- IEC 61331:2010
- IEC 61332:2010
- IEC 61333:2010
- IEC 61334:2010
- IEC 61335:2010
- IEC 61336:2010
- IEC 61337:2010
- IEC 61338:2010
- IEC 61339:2010
- IEC 61340:2010
- IEC 61341:2010
- IEC 61342:2010
- IEC 61343:2010
- IEC 61344:2010
- IEC 61345:2010
- IEC 61346:2010
- IEC 61347:2010
- IEC 61348:2010
- IEC 61349:2010
- IEC 61350:2010
- IEC 61351:2010
- IEC 61352:2010
- IEC 61353:2010
- IEC 61354:2010
- IEC 61355:2010
- IEC 61356:2010
- IEC 61357:2010
- IEC 61358:2010
- IEC 61359:2010
- IEC 61360:2010
- IEC 61361:2010
- IEC 61362:2010
- IEC 61363:2010
- IEC 61364:2010
- IEC 61365:2010
- IEC 61366:2010
- IEC 61367:2010
- IEC 61368:2010
- IEC 61369:2010
- IEC 61370:2010
- IEC 61371:2010
- IEC 61372:2010
- IEC 61373:2010
- IEC 61374:2010
- IEC 61375:2010
- IEC 61376:2010
- IEC 61377:2010
- IEC 61378:2010
- IEC 61379:2010
- IEC 61380:2010
- IEC 61381:2010
- IEC 61382:2010
- IEC 61383:2010
- IEC 61384:2010
- IEC 61385:2010
- IEC 61386:2010
- IEC 61387:2010
- IEC 61388:2010
- IEC 61389:2010
- IEC 61390:2010
- IEC 61391:2010
- IEC 61392:2010
- IEC 61393:2010
- IEC 61394:2010
- IEC 61395:2010
- IEC 61396:2010
- IEC 61397:2010
- IEC 61398:2010
- IEC 61399:2010
- IEC 61400:2010
- IEC 61401:2010
- IEC 61402:2010
- IEC 61403:2010
- IEC 61404:2010
- IEC 61405:2010
- IEC 61406:2010
- IEC 61407:2010
- IEC 61408:2010
- IEC 61409:2010
- IEC 61410:2010
- IEC 61411:2010
- IEC 61412:2010
- IEC 61413:2010
- IEC 61414:2010
- IEC 61415:2010
- IEC 61416:2010
- IEC 61417:2010
- IEC 61418:2010
- IEC 61419:2010
- IEC 61420:2010
- IEC 61421:2010
- IEC 61422:2010
- IEC 61423:2010
- IEC 61424:2010
- IEC 61425:2010
- IEC 61426:2010
- IEC 61427:2010
- IEC 61428:2010
- IEC 61429:2010
- IEC 61430:2010
- IEC 61431:2010
- IEC 61432:2010
- IEC 61433:2010
- IEC 61434:2010
- IEC 61435:2010
- IEC 61436:2010
- IEC 61437:2010
- IEC 61438:2010
- IEC 61439:2010
- IEC 61440:2010
- IEC 61441:2010
- IEC 61442:2010
- IEC 61443:2010
- IEC 61444:2010
- IEC 61445:2010
- IEC 61446:2010
- IEC 61447:2010
- IEC 61448:2010
- IEC 61449:2010
- IEC 61450:2010
- IEC 61451:2010
- IEC 61452:2010
- IEC 61453:2010
- IEC 61454:2010
- IEC 61455:2010
- IEC 61456:2010
- IEC 61457:2010
- IEC 61458:2010
- IEC 61459:2010
- IEC 61460:2010
- IEC 61461:2010
- IEC 61462:2010
- IEC 61463:2010
- IEC 61464:2010
- IEC 61465:2010
- IEC 61466:2010
- IEC 61467:2010
- IEC 61468:2010
- IEC 61469:2010
- IEC 61470:2010
- IEC 61471:2010
- IEC 61472:2010
- IEC 61473:2010
- IEC 61474:2010
- IEC 61475:2010
- IEC 61476:2010
- IEC 61477:2010
- IEC 61478:2010
- IEC 61479:2010
- IEC 61480:2010
- IEC 61481:2010
- IEC 61482:2010
- IEC 61483:2010
- IEC 61484:2010
- IEC 61485:2010
- IEC 61486:2010
- IEC 61487:2010
- IEC 61488:2010
- IEC 61489:2010
- IEC 61490:2010
- IEC 61491:2010
- IEC 61492:2010
- IEC 61493:2010
- IEC 61494:2010
- IEC 61495:2010
- IEC 61496:2010
- IEC 61497:2010
- IEC 61498:2010
- IEC 61499:2010
- IEC 61500:2010
- IEC 61501:2010
- IEC 61502:2010
- IEC 61503:2010
- IEC 61504:2010
- IEC 61505:2010
- IEC 61506:2010
- IEC 61507:2010
- IEC 61508:2010
- IEC 61509:2010
- IEC 61510:2010
- IEC 61511:2010
- IEC 61512:2010
- IEC 61513:2010
- IEC 61514:2010
- IEC 61515:2010
- IEC 61516:2010
- IEC 61517:2010
- IEC 61518:2010
- IEC 61519:2010
- IEC 61520:2010
- IEC 61521:2010
- IEC 61522:2010
- IEC 61523:2010
- IEC 61524:2010
- IEC 61525:2010
- IEC 61526:2010
- IEC 61527:2010
- IEC 61528:2010
- IEC 61529:2010
- IEC 61530:2010
- IEC 61531:2010
- IEC 61532:2010
- IEC 61533:2010
- IEC 61534:2010
- IEC 61535:2010
- IEC 61536:2010
- IEC 61537:2010
- IEC 61538:2010
- IEC 61539:2010
- IEC 61540:2010
- IEC 61541:2010
- IEC 61542:2010
- IEC 61543:2010
- IEC 61544:2010
- IEC 61545:2010
- IEC 61546:2010
- IEC 61547:2010
- IEC 61548:2010
- IEC 61549:2010
- IEC 61550:2010
- IEC 61551:2010
- IEC 61552:2010
- IEC 61553:2010
- IEC 61554:2010
- IEC 61555:2010
- IEC 61556:2010
- IEC 61557:2010
- IEC 61558:2010
- IEC 61559:2010
- IEC 61560:2010
- IEC 61561:2010
- IEC 61562:2010
- IEC 61563:2010
- IEC 61564:2010
- IEC 61565:2010
- IEC 61566:2010
- IEC 61567:2010
- IEC 61568:2010
- IEC 61569:2010
- IEC 61570:2010
- IEC 61571:2010
- IEC 61572:2010
- IEC 61573:2010
- IEC 61574:2010
- IEC 61575:2010
- IEC 61576:2010
- IEC 61577:2010
- IEC 61578:2010
- IEC 61579:2010
- IEC 61580:2010
- IEC 61581:2010
- IEC 61582:2010
- IEC 61583:2010
- IEC 61584:2010
- IEC 61585:2010
- IEC 61586:2010
- IEC 61587:2010
- IEC 61588:2010
- IEC 61589:2010
- IEC 61590:2010
- IEC 61591:2010
- IEC 61592:2010
- IEC 61593:2010
- IEC 61594:2010
- IEC 61595:2010
- IEC 61596:2010
- IEC 61597:2010
- IEC 61598:2010
- IEC 61599:2010
- IEC 61600:2010
- IEC 61601:2010
- IEC 61602:2010
- IEC 61603:2010
- IEC 61604:2010
- IEC 61605:2010
- IEC 61606:2010
- IEC 61607:2010
- IEC 61608:2010
- IEC 61609:2010
- IEC 61610:2010
- IEC 61611:2010
- IEC 61612:2010
- IEC 61613:2010
- IEC 61614:2010
- IEC 61615:2010
- IEC 61616:2010
- IEC 61617:2010
- IEC 61618:2010
- IEC 61619:2010
- IEC 61620:2010
- IEC 61621:2010
- IEC 61622:2010
- IEC 61623:2010
- IEC 61624:2010
- IEC 61625:2010
- IEC 61626:2010
- IEC 61627:2010
- IEC 61628:2010
- IEC 61629:2010
- IEC 61630:2010
- IEC 61631:2010
- IEC 61632:2010
- IEC 61633:2010
- IEC 61634:2010
- IEC 61635:2010
- IEC 61636:2010
- IEC 61637:2010
- IEC 61638:2010
- IEC 61639:2010
- IEC 61640:2010
- IEC 61641:2010
- IEC 61642:2010
- IEC 61643:2010
- IEC 61644:2010
- IEC 61645:2010
- IEC 61646:2010
- IEC 61647:2010
- IEC 61648:2010
- IEC 61649:2010
- IEC 61650:2010
- IEC 61651:2010
- IEC 61652:2010
- IEC 61653:2010
- IEC 61654:2010
- IEC 61655:2010
- IEC 61656:2010
- IEC 61657:2010
- IEC 61658:2010
- IEC 61659:2010
- IEC 61660:2010
- IEC 61661:2010
- IEC 61662:2010
- IEC 61663:2010
- IEC 61664:2010
- IEC 61665:2010
- IEC 61666:2010
- IEC 61667:2010
- IEC 61668:2010
- IEC 61669:2010
- IEC 61670:2010
- IEC 61671:2010
- IEC 61672:2010
- IEC 61673:2010
- IEC 61674:2010
- IEC 61675:2010
- IEC 61676:2010
- IEC 61677:2010
- IEC 61678:2010
- IEC 61679:2010
- IEC 61680:2010
- IEC 61681:2010
- IEC 61682:2010
- IEC 61683:2010
- IEC 61684:2010
- IEC 61685:2010
- IEC 61686:2010
- IEC 61687:2010
- IEC 61688:2010
- IEC 61689:2010
- IEC 61690:2010
- IEC 61691:2010
- IEC 61692:2010
- IEC 61693:2010
- IEC 61694:2010
- IEC 61695:2010
- IEC 61696:2010
- IEC 61697:2010
- IEC 61698:2010
- IEC 61699:2010
- IEC 61700:2010
- IEC 61701:2010
- IEC 61702:2010
- IEC 61703:2010
- IEC 61704:2010
- IEC 61705:2010
- IEC 61706:2010
- IEC 61707:2010
- IEC 61708:2010
- IEC 61709:2010
- IEC 61710:2010
- IEC 61711:2010
- IEC 61712:2010
- IEC 61713:2010
- IEC 61714:2010
- IEC 61715:2010
- IEC 61716:2010
- IEC 61717:2010
- IEC 61718:2010
- IEC 61719:2010
- IEC 61720:2010
- IEC 61721:2010
- IEC 61722:20

CLIENTELE

DICABS

POWERING PROGRESS





Diamond Power Infrastructure Limited

Corporate Office

Westgate (True Value) Block D, Office No. : 1703 to 1707, Nr. YMCA Club,
SG Highway, Makarba, Ahmedabad - 380 051, Gujarat, India.
T: +91 8411966239

New Delhi: 4th Floor, 404-A, World Trade Centre, Babar Road, New Delhi - 110001
Akshat Bhatnagar - +91 8802113399

Mumbai: Prashant Tiwari - +91 9819103988

Factory

Vadadala, PHASE - II, Savli, Vadodara, Gujarat, India.
T: 02667 251516 F: 02667 251202

E-Mail: enquiry@dicabs.com • exports@dicabs.com



SCAN QR CODE TO VISIT WEBSITE



www.dicabs.com